



## ZET UW RAILINGSYSTEEM IN DE SPOTLIGHTS.

Handrailingen

### Q-LIGHTS - LED-spots

Voor buis 42,4 x 2,0 mm



Asymmetrische lichtbundel  
Kleurtemperatuur 5000K  
500 mA LED-driver  
2W, 24V  
50.000 branduren

**MOD 0050**

IN/OUTDOOR

41.0050.242.12



Kijk op pagina 237 voor buizen van 42,4 x 2,0 mm en 48,3 x 2,0 mm.

Q-INFO

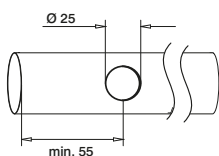

We raden u aan om het gat in de buis te frezen. Is dat niet mogelijk, gebruik dan een stappenboor. Schuur of polijst ieder gat na het boren en verwijder metaalresten om snoerbeschadiging te voorkomen. Start met het installeren van de LED-spots nadat u alle gaten van binnen en van buiten heeft afgebraamd.

Voor buis 48,3 x 2,0 mm



Asymmetrische lichtbundel  
Kleurtemperatuur 5000K  
500 mA LED-driver  
2W, 24V  
50.000 branduren

**MOD 0050**

IN/OUTDOOR

41.0050.248.12



Prefix: zie pagina 380.

Q-INFO

Bescherming tegen kortsluiting en oververhitting



Unieke klik-technologie

De LED-spots zijn niet geschikt om onder water te gebruiken. Houd alle veiligheidsvoorschriften in acht, u vindt deze op pagina 361.

Goede warmteverdeling dankzij koelelement

IP siliconenaafdichting

Q-LIGHTS - LED-spots - Montage

Q-INFO

Set: 41.0050.24x.12

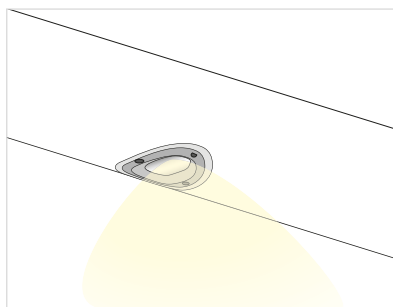
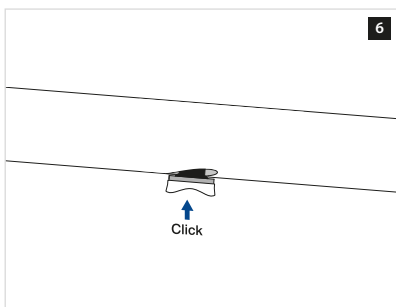
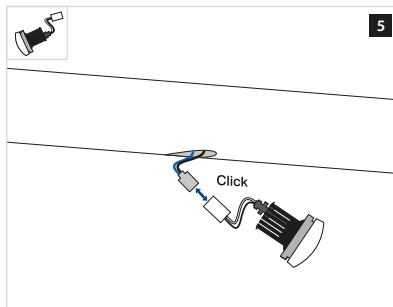
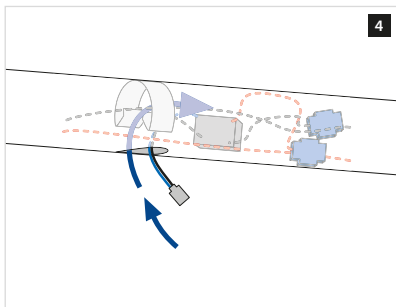
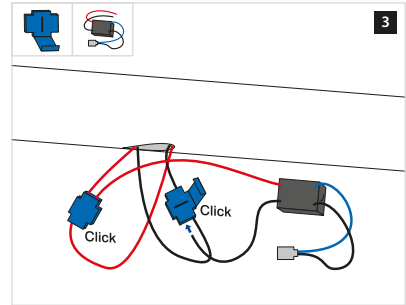
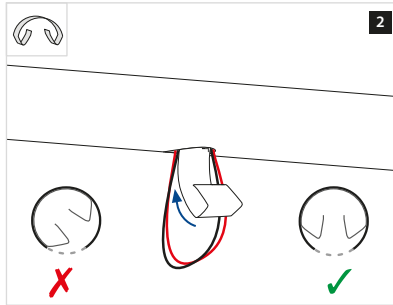
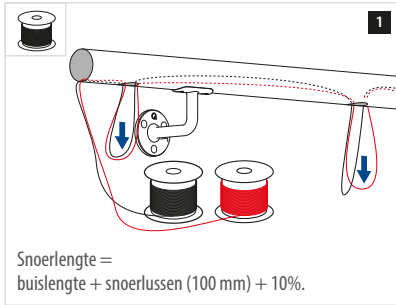
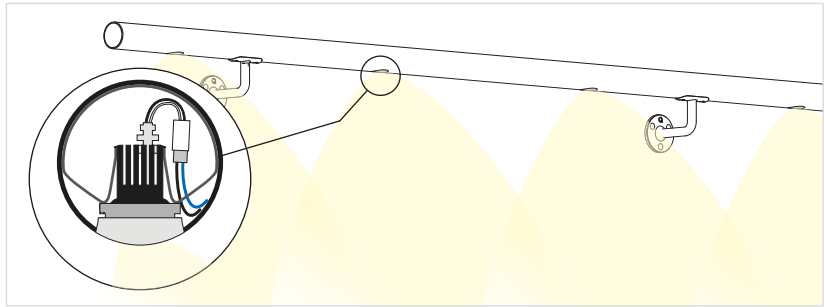
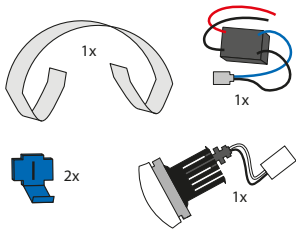

Baluster-  
railingssystemen

Q-INFO

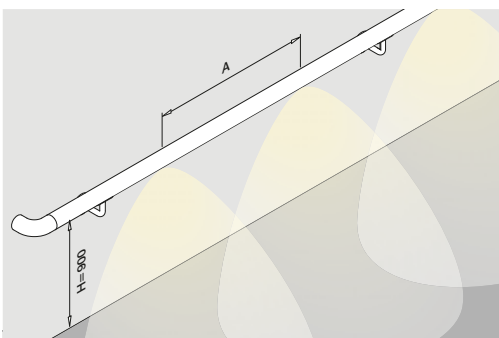

Voor het beste lichtresultaat adviseren wij u een afstand van 600 mm tussen de LED-spots.

Lichtsterkte van een 900 mm hoge handrailing op vloer of trap

		Afstand (A) tussen LED-spots (mm)			
		400	600	1000	1200
Afstand vanaf de muur (mm)	0	241 lx	165 lx	98 lx	96 lx
	600	200 lx	120 lx	80 lx	60 lx
	1000	150 lx	80 lx	40 lx	40 lx
	1500	100 lx	40 lx	20 lx	20 lx

Ter vergelijking  
 Direct zonlicht = 100.000 lx  
 Een bewolkte dag = 1.000 lx  
 Verlichting in een hal = 100 lx  
 Licht van een straatlantaarn = 10 lx  
 Kaarslicht op circa 1 meter afstand = 1 lx

De genoemde waarden zijn indicatief.

Wij raden u aan met een lichtconsultant of electricien het systeem exact op uw project en de parameters ter plaatse af te stemmen.



## RAILINGSYSTEMEN IN EEN ANDER LICHT.

Handrailingen

### Q-LIGHTS - LED-spots - Kabellayout

Q-INFO

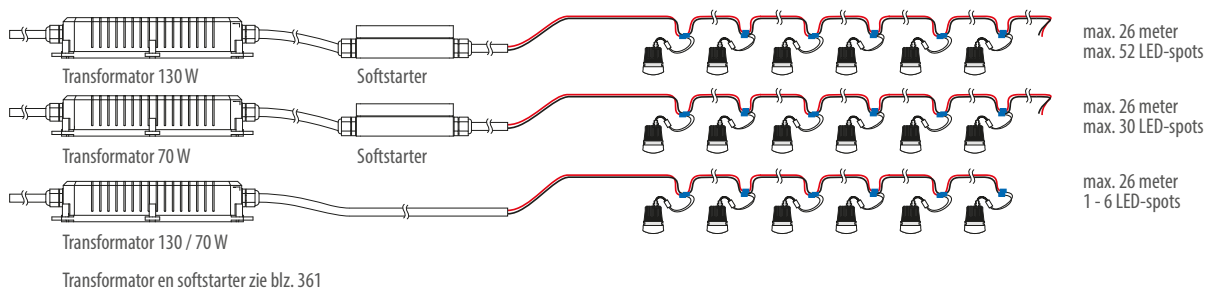

Handrailingen

### Q-LIGHTS - LED-spots - Demontage

Q-INFO

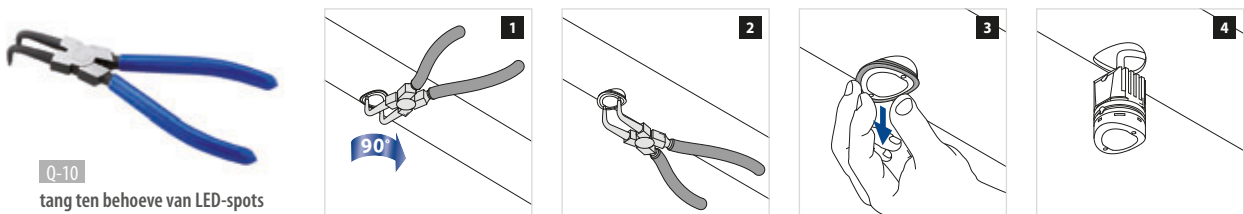

Wand - buis

Met kabeldoorvoer

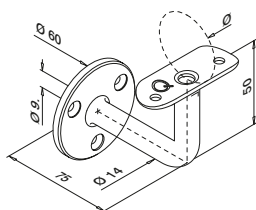

**MOD 0103**

**304**

INDOOR	Ø			
13.0103.042.12	42,4	QS-7	348 / QS-10	348 2
13.0103.048.12	48,3	QS-7	348 / QS-10	348 2

**316**

OUTDOOR	Ø			
14.0103.042.12	42,4	QS-6	348 / QS-11	348 2
14.0103.048.12	48,3	QS-6	348 / QS-11	348 2



Met kabeldoorvoer

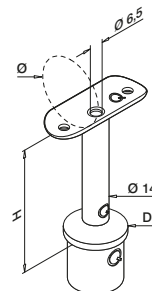

**MOD 0710**

**316**

OUTDOOR	D	Ø	H		
14.0710.642.12	42,4 x 2,0	42,4	79	QS-11	350 2

**MOD 0711**

**316**

OUTDOOR	D	Ø	H		
14.0711.648.12	48,3 x 2,0	48,3	80	QS-11	348 2



Q-INFO MOD 0103

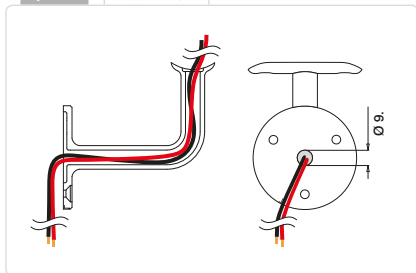

Q-INFO MOD 0710.6xx

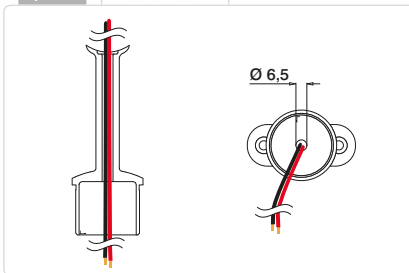

Q-INFO MOD 0103

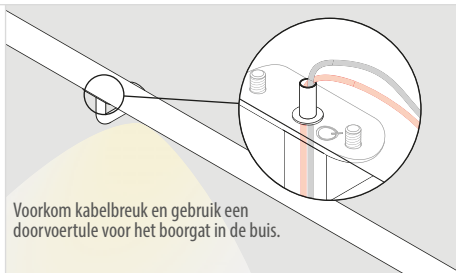
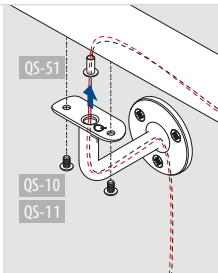
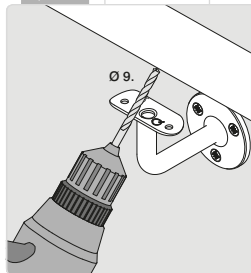

Q-INFO MOD 0103/0710

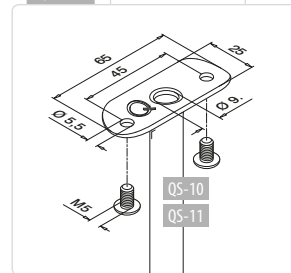



# Q-LIGHTS.

Handrailingen

GESLEPEN

Q-LINE - Verbinders, flexibel



0 - 70°

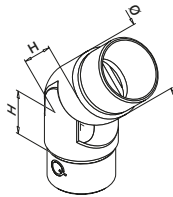

### MOD 0312

304

INDOOR	Ø	H	
13.0312.242.12	42,4 x 2,0	27	2
13.0312.248.12	48,3 x 2,0	30	2

316

OUTDOOR	Ø	H	
14.0312.242.12	42,4 x 2,0	27	2
14.0312.248.12	48,3 x 2,0	30	2



Design  
product

International Design Model Protection

Q-INFO

MOD 0312

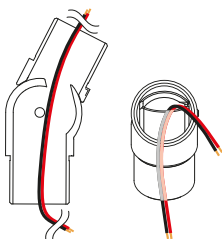

Q-INFO



Q-22

Q-ultra-clean  
500 ml  
19.0610.000.00

Buis - buis

Met kabeldoorvoer

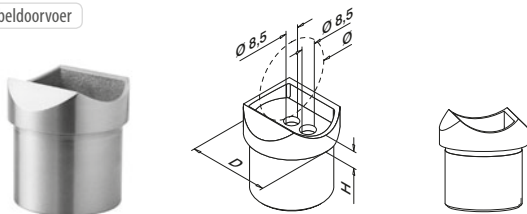
**MOD 0772** - D = Ø 42,4 mm

304

INDOOR	D	Ø	H		
13.0772.242.12	Ø 42,4 x 2,0	42,4	9	QS-26	349 2

316

OUTDOOR	D	Ø	H		
14.0772.242.12	Ø 42,4 x 2,0	42,4	9	QS-27	349 2

**MOD 0771** - D = Ø 48,3 mm

304

INDOOR	D	Ø	H		
13.0771.248.12	Ø 48,3 x 2,0	48,3	11	QS-26	349 2

316

OUTDOOR	D	Ø	H		
14.0771.248.12	Ø 48,3 x 2,0	48,3	11	QS-27	349 2



Baluster MOD 0914 en afdekkap MOD 0512 zie blz. 218.

Wand - buis

Met kabeldoorvoer

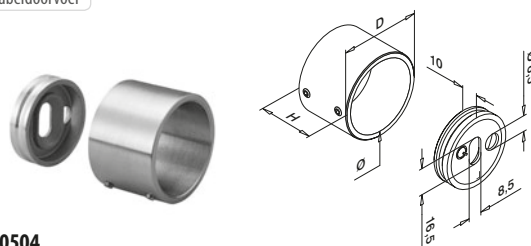
**MOD 0504**

304

INDOOR	Ø	D	H		
13.0504.042.12	42,4	50	35	QS-55	351 / QS-21 349 2
13.0504.048.12	48,3	56	35	QS-55	351 / QS-21 349 2

316

OUTDOOR	Ø	D	H		
14.0504.042.12	42,4	50	35	QS-55	351 / QS-22 349 2
14.0504.048.12	48,3	56	35	QS-55	351 / QS-22 349 2



## Q-INFO MOD 0772 / 0771

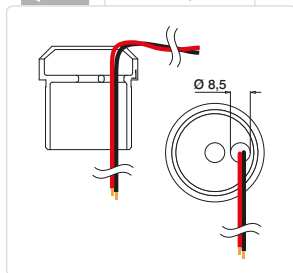

## Q-INFO MOD 0772 / 0771

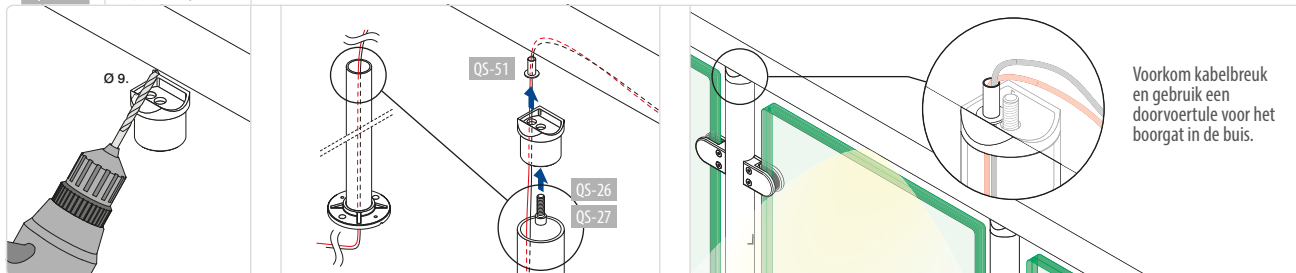

## Q-INFO MOD 0504

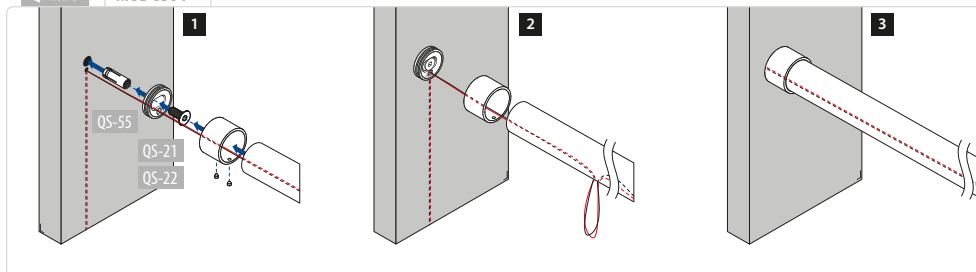

## Q-INFO MOD 0504

